

TEMPEST™

OPERATIONS MANUAL Original Instructions

Power Blowers™
Cone Air Flow (CAF) - Gasoline Driven

Direct-Drive Series

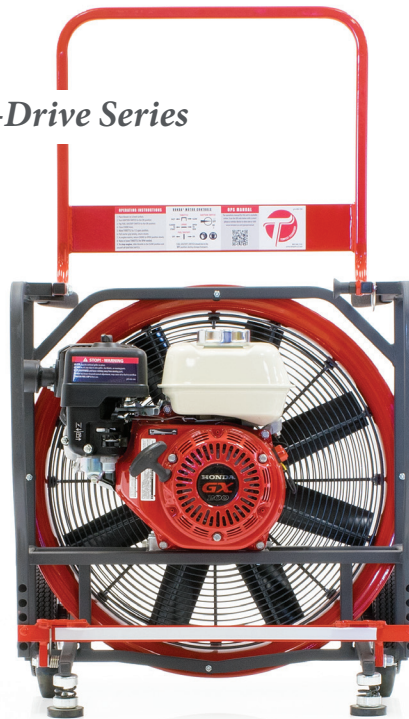

EN

Read this manual carefully, before the first use

INTRODUCTION

Thank you for choosing Tempest Technology Corporation for your ventilation needs. With this manual we hope to help you operate your Tempest product safely and to its full potential. Maintained according to the specifications set in this manual and the engine manufacturer’s manual, it is not uncommon to receive many years of use and operation out of your Tempest equipment.

This manual is produced solely for the use of purchasers and operators of Tempest Technology Corporation equipment. Any reproduction, retransmission, or other use of the contents of this manual without written consent of Tempest Technology Corporation is strictly prohibited.

It is the intent of this manual to provide the owner/operator of Tempest Technology Corporation products with both general and specific information regarding the safe and proper operation and maintenance of the equipment described within.

CONTACT

If after careful review, any questions arise concerning any portion of this manual, please contact Tempest Technology Corporation for assistance:

TEMPEST TECHNOLOGY CORP.
4708 N. BLYTHE AVENUE
FRESNO, CA 93722 USA

t: +1.559.277.7577
f: +1.559.277.7579

response@tempest.us.com
www.tempest.us.com

TABLE OF CONTENTS

ABOUT TEMPEST	2
SAFETY GUIDE	3
GENERAL INFORMATION	3
POWER BLOWER™ DATA	4
POWER BLOWER™ INFORMATION	5
OPERATING PROCEDURES	5
MAINTENANCE PROCEDURES	6
POWER BLOWER™ TROUBLESHOOTING	8
REPLACEMENT PARTS - Direct-Drive	9
NOTES	10
WARRANTY	BACK COVER

ABOUT TEMPEST

Tempest Technology Corporation is the leading manufacturer of products and accessories for environmental management in firefighting and industrial applications.

Tempest began as a manufacturer of gasoline and electric powered blowers for the fire service. Fire departments use the **Tempest Power Blower™** to provide “Positive Pressure Ventilation / Attack” (PPV/PPA) to remove heat, gases and smoke from the interior of a burning structure.

Tempest has expanded into other industries and found new applications for its products. The **Tempest Power Blower™** and PPV/PPA are used by industrial applications to control dust, fumes and unhealthy gases like carbon monoxide, greatly improving safety in confined spaces.

Tempest Technology Corporation has earned a reputation as a leader and innovator in the air movement industry and continues in that role today.

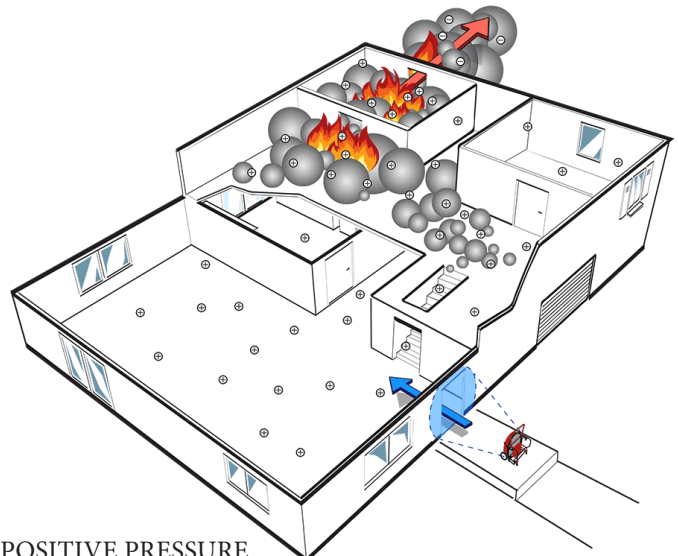

POSITIVE PRESSURE
VENTILATION/ATTACK

SAFETY GUIDE

This equipment is designed and manufactured in compliance with CE directives. This equipment should be used only by firefighting professionals

Failure to follow the operating, maintenance and lubrication requirements set forth in this manual and the engine manufacturer's owner's manual may result in serious personal injury or death and/or damage to equipment or property.

The following WARNING statements indicate potentially hazardous conditions for operators and equipment. Make certain that anyone who works on or around the blower has read and fully understands the safety precautions listed.

1. Carefully read this owner's manual before attempting to operate, service or disassemble any part of your *Tempest Power Blower™*.
2. Carefully read the Honda® engine owner's manual that has been supplied with your blower for specific information and maintenance about your engine.
3. **DO NOT** operate the unit when mentally or physically fatigued or impaired.
4. Stay away from rotating parts; Do not wear loose clothes that could be caught by the fan; jackets, shirts, ties. Keep hands and feet away from moving parts.
5. Keep all unauthorized personnel at a safe distance from the blower.
6. Keep all guards in place. **DO NOT** make repairs while the unit is running. **DO NOT** operate if any guard or grill is not in place or are damaged.
7. Always wear eye protection. **DO NOT** stand in discharge air stream. Loose debris can be picked up in the air stream and flown in the air.
8. Hearing protection is required. Engine and air noise may exceed safe dB levels.
9. Gasoline is extremely flammable and is explosive under certain conditions. To prevent fire hazards, do not place flammable objects close to the engine.
10. Do not overfill the fuel tank. After refueling, make sure the tank cap is closed properly and secured. If any fuel is spilled, make sure the area is dry before starting the engine.
11. Never operate gasoline-powered blowers in an enclosed or confined area. Exhaust contains poisonous carbon monoxide gas; exposure may cause loss of consciousness and may lead to death.
12. The muffler becomes very hot during operation and remains hot for some time after stopping the engine. Be careful not to touch the muffler while it is hot. To avoid severe burns or fire hazards, let the engine cool before transporting or storing the unit.
13. It is the sole responsibility of the owner/operator to develop procedures for proper use of the *Tempest Power Blower™* in accordance with generally accepted ventilation techniques as well as the organization's own operating procedures, before placing the unit into service.



GENERAL INFORMATION

BLOWER IDENTIFICATION

Each *Tempest Power Blower™* has a part number as well as a serial number. The part number identifies the type of unit (size, drive, etc.) while the serial number relates to information referencing the date of manufacture. This information is useful should it become necessary to contact the factory regarding your *Power Blower™*.

SERIAL NUMBER LOCATIONS

The serial number is typically located on the frame just right of the engine mount (when viewed from behind).

Please write the Serial Number of your *Tempest Power Blower™* in the spaces below. This will aid us in identifying which model you have when assisting you.

Model (Part No.) _____

Date _____

Serial No. _____

WARRANTY

Warranty information on your unit can be found on the back page of this manual. For further information, please contact Tempest Technology Corp.

POWER BLOWER™ DATA

TYPE:	Positive Pressure Ventilation Fan, Cone Air Flow (CAF)
DRIVE:	16" Models: Direct-Drive - HONDA® GX160 18" Models: Direct-Drive - HONDA® GX160 21" Models: Direct-Drive - HONDA® GX200 24" Models: Direct-Drive - HONDA® GX200
GAS ENGINES:	TYPE: Single Cylinder, 4 Stroke, Gasoline COOLING: Forced Air LUBRICATION: Splash Type Oil Reservoir STARTING: Recoil with Auto Rewind
BLADE:	AirFlex Fiberglass Reinforced Polyamide Blades
BUSHING:	Keyed Shaft and Set or Cap Screws
SHROUD:	Turbo 2000 Tapered Aluminum w/ Durable Powder-Coat Finish
FRAME:	Rugged, Lightweight, Square-Steel Tubing with Powder-Coat Finish
TILT MECHANISM:	Foot-Operated Tilt Mechanism 16" Models: Four Position Tilt, +10°, +5°, 0°, -5° 18", 21", 24" Models: Five Position Tilt, +15°, +10°, +5°, 0°, -5°
GRILLE:	Continuous Circular-Wound, External-Weld Steel Wire with 8 Tie Points for Additional Safety Meets UL & European CE Safety Standards
VIBRATION DAMPENERS:	Steel-Reinforced Rubber and Steel Spring Feet
WHEELS: (NON-BASIC)	16" Models: 6" Non-Pneumatic w/ Steel Hubs 18", 21", and 24" Models: 8" Non-Pneumatic w/ Steel Hubs

DIRECT-DRIVE SPECIFICATIONS:	Model No.	Part No.	Size	HP	m³h	Dimensions (WxDxH)(cm)	Weight (dry)
	DD-16-H-4.8	921-1100	16"	4.8	20,400	52.1 x 50.2 x 55.3	36 kg
	DD-18-H-4.8	921-1120	18"	4.8	25,100	57.8 x 53.4 x 61.6	39 kg
	DD-21-H-5.5	921-1140	21"	5.5	34,238	63.5 x 53.4 x 66.7	41 kg
	DD-24-H-5.5	921-1160	24"	5.5	33,310	71.8 x 53.4 x 76.2	45 kg

NOISE LEVEL @ 3 METERS:	DD-16-H-4.8	921-1100	90 to 97 db(A)
	DD-18-H-4.8	921-1120	92 to 98 db(A)
	DD-21-H-5.5	921-1140	94 to 101 db(A)
	DD-24-H-5.5	921-1160	94 to 101 db(A)

POWER BLOWER™ INFORMATION

The *Tempest Power Blower™* is a high powered, portable fan used for Positive Pressure Ventilation and Attack (PPV/PPA), ventilation techniques that quickly and efficiently replace hazardous interior environments with clean, cool air.

PPV and PPA were pioneered in the firefighting industry where firefighters use the *Tempest Power Blower™* to ventilate smoke, heat, and harmful gases from buildings. This creates a safer environment for them to work in and makes it easier for them to find victims and extinguish the fire.

PPV and PPA rely on two principles, (1) an air pattern capable of creating an effective door seal, and (2) pressure. To accomplish Positive Pressure Ventilation or Attack, the blower is placed on the outside of the structure. It is positioned so that the air pattern created by the blower completely seals the entrance opening, or at least 2/3 of it. When this seal is achieved, the air pressure is increased equally at all points inside the structure. When an exhaust opening is created, all of the interior air moves in one mass towards it. The result is fast, efficient ventilation of the entire structure.

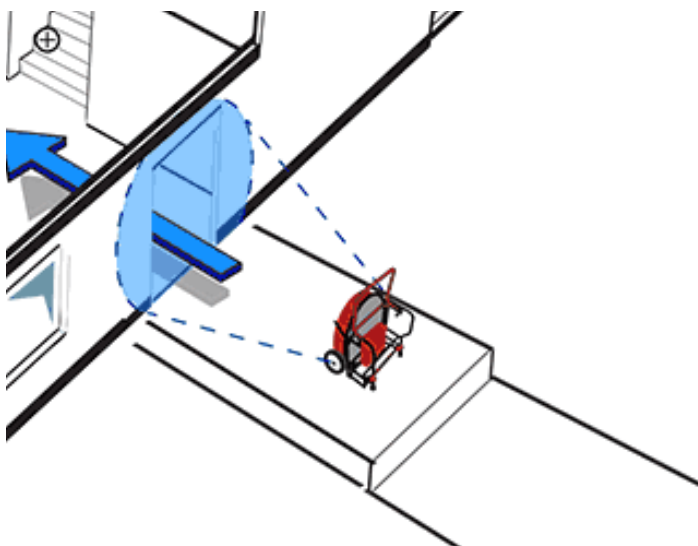

NOTE: The *Tempest Power Blower™* is the most efficient tool for PPV and PPA for two reasons. First, the exclusive Tempest Turbo 2000 tapered shroud design creates a wide, stable, conical air pattern. Second, the airflex impeller used on all Tempest blowers is designed to create high pressure. These two features working together make the *Tempest Power Blower™* a highly effective and efficient ventilation tool.

As with any new technique, Positive Pressure Ventilation requires training and education in order to be implemented properly and safely. Tempest offers access to a complete line of training materials, which cover many applications for this powerful ventilation technique. For more information visit www.tempest.us.com, www.positivepressuretraining.com or contact us at 800.346.2143 or response@tempest.us.com.

OPERATING PROCEDURES

PRE-OPERATION

VISUAL INSPECTION

After receiving and unpacking your blower, be sure to carefully inspect it for any damage that might have occurred during shipping. Should you find any damage: PLEASE NOTIFY TEMPEST TECHNOLOGY CORP. IMMEDIATELY AT 800.346.2143 OR RESPONSE@TEMPEST.US.COM.

ENGINE OIL

Be sure to use only high quality detergent oil. Detergent oils keep the engine cleaner and retards the formation of gum and varnish deposits.

RECOMMENDED OILS

HONDA® engines: SF or SG SAE 10W-30 oil.

ENGINE	CAPACITY
HONDA® GX120	0.59 US Quarts / 0.56 Liters
HONDA® GX160	0.61 US Quarts / 0.58 Liters
HONDA® GX200	0.63 US Quarts / 0.60 Liters

FILLING THE CRANKCASE

Place blower on a level surface and make sure that the engine is level. Remove the oil fill plug or dipstick. POUR OIL SLOWLY into the crankcase. Replace oil fill plug or dipstick and tighten securely. Refer to the engine manufacturer's owner's manual for additional information regarding specific oil requirements.

⚠ CAUTION: DO NOT OVERFILL THE ENGINE. EXCESS OIL VAPOR CAN BE EJECTED FROM THE ENGINE BREATHER WHILE RUNNING.

FUEL

Always use clean, fresh, lead-free gasoline with an (R+M)/2 octane rating of 86 or higher. DO NOT USE leaded gasolines. Refer to the engine manufacturer's owner's manual for acceptable substitute gasolines.

⚠ CAUTION: PRECAUTIONS MUST BE FOLLOWED WHENEVER REFUELING GASOLINE ENGINES. PLEASE FOLLOW THE LISTED GUIDELINES.

- **DO NOT FILL THE FUEL TANK INDOORS.**
- **DO NOT FILL THE FUEL TANK WHILE THE ENGINE IS RUNNING OR HOT.**
- **DO NOT SMOKE DURING REFUELING.**
- **DO NOT FILL THE FUEL TANK COMPLETELY. FILL THE TANK TO THE DESIGNATED LEVEL. OVERFILLING WILL CLOG THE CHARCOAL FILTER LOCATED IN THE FUEL CAP, INHIBITING THE FLOW OF FUEL.**
- **WIPE ANY SPILLAGE FROM ENGINE AND COMPONENTS BEFORE STARTING THE ENGINE.**

FUEL CAPACITY

ENGINE	CAPACITY
HONDA® GX120	2.1 US Quarts / 2.0 Liters
HONDA® GX160	3.3 US Quarts / 3.1 Liters
HONDA® GX200	3.3 US Quarts / 3.1 Liters

OPERATION

SET-UP, STARTING AND STOPPING

Assuming the previous Pre-Operation and safety instructions have been followed, the blower is now ready to run. Please review the engine manufacturer's owner's manual regarding starting and stopping as well as the instructions in this section before actually starting the blower.



CAUTION: DO NOT MOVE THE BLOWER WHILE IT IS IN OPERATION. SEVERE PERSONAL INJURY IS POSSIBLE AS WELL AS DAMAGE TO THE BLOWER.

ALWAYS SHUT-DOWN THE BLOWER PRIOR TO MOVING.

SET-UP

Position the blower in the desired location, making sure it is placed on a flat, hard and debris free surface.

STARTING

1. Turn IGNITION SWITCH to the ON position
2. Flip FUEL SHUTOFF SWITCH to the ON position.
3. Close CHOKE lever.
4. Move THROTTLE to 1/2 open position.
5. Pull starter grip briskly, return slowly.
6. As engine warms, return CHOKE to OPEN position slowly.
7. Raise or lower THROTTLE for RPM needed.

STOPPING

1. To stop engine, slide throttle to the SLOW position and shutoff IGNITION SWITCH.

NOTE: The FUEL SHUTOFF SWITCH must be in the OFF position during storage and any time the blower is moved or transported.

HANDLE OPERATION

To operate the handle, pull the locking pin and rotate the handle to the full up or full down position, release the pin and make sure the pin locks in place.



TILT OPERATION

While standing behind the blower and holding the handle, step on the foot pad on the tilt adjustment mechanism to release it from the frame. Tilt the blower to one of the available angle positions. Take your foot off of the foot pad and allow the pins of the tilt mechanism to lock in place with the holes in the frame.

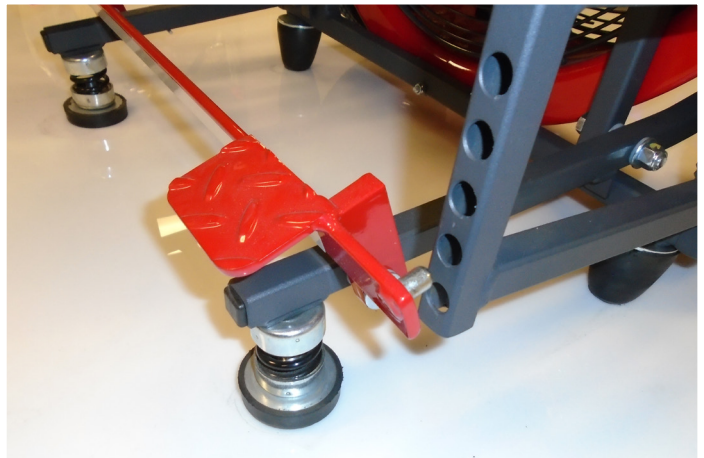

MAINTENANCE PROCEDURES

Proper maintenance is necessary to ensure that your **Power Blower™** operates as efficiently and trouble-free as possible. By following the instructions in this section you will be providing the maintenance needed to achieve this goal. Detailed engine maintenance instructions can be found in the engine manufacturer's owner's manual.

⚠ CAUTION: THE ENGINE MAY START SIMPLY BY ROTATING THE BLADES. ALWAYS REMOVE THE SPARK PLUG WIRE PRIOR TO WORKING ON THE BLADE SIDE OF THE MOTOR.

MAINTENANCE SCHEDULE

EVERY USE

- Check engine oil
- Check air cleaner
- Inspect blower for damage and fix if any
- Tighten/replace any loose, damaged, or missing parts

FIRST MONTH OR 20 HOURS

- Change engine oil

EVERY MONTH OR 20 HOURS

- Inspect & clean engine housing

EVERY THREE (3) MONTHS OR 50 HOURS

- Clean air filter

EVERY SIX (6) MONTHS OR 100 HOURS

- Change engine oil
- Inspect & clean spark plug

EVERY YEAR OR 300 HOURS

- Replace spark plug

⚠ IMPORTANT: Always operate the blower in an area free of debris which may be pulled into the unit's blades. If you suspect the fan's blade may have contacted a hard object, thorough inspection of the blade assembly should be conducted immediately to ensure safety. You may contact Tempest Technology Corp. in order to find out how to properly inspect the blade assembly.

OIL CHANGE

Check the engine oil level before each use. The oil should be changed after the first month or 20 operating hours and every six (6) months or 100 hours thereafter. Oil changes should be performed more frequently if the blower is being operated in dusty or dirty conditions. Changing the oil is easier when the engine is still warm (not hot) from a recent running.

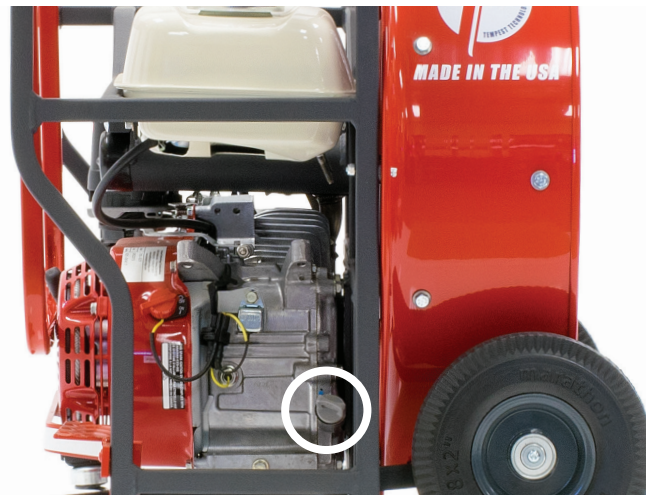

OIL FILLER CAP

PROCEDURES

1. Position the blower so the engine oil drain plug is the lowest point on the engine.
2. Place a two quart or larger container under the oil drain plug for the oil to drain into.
3. Remove the oil drain plug and drain the used oil.
4. Install the oil drain plug and tighten securely.
5. Remove the oil filler cap and refill with the recommended oil (refer to the Pre-Operation instructions in the Operations section) and check the oil level.

AIR CLEANER

A dirty air cleaner will restrict airflow to the carburetor. To prevent carburetor malfunction, service the air cleaner regularly. More frequent service may be necessary when the blower is operated in extremely dusty conditions.

⚠ CAUTION: DO NOT RUN THE ENGINE WITH THE AIR CLEANER REMOVED. RAPID ENGINE WEAR WILL RESULT FROM CONTAMINANTS, SUCH AS DUST AND DIRT BEING DRAWN THROUGH THE CARBURETOR AND INTO THE ENGINE.

CLEANING AIR FILTER ELEMENTS

Foam Element:

1. Wash the element in a solution of household detergent and warm water, then rinse thoroughly. Allow the element to dry completely.
2. Soak the element in clean engine oil, and squeeze out the excess oil.

NOTE: the engine will smoke during initial start-up if too much oil is left in the foam element.

Paper Element:

1. To remove excess dirt, tap the element lightly several times on a hard surface or blow compressed air through the filter from the inside out.
2. Do not try to brush the dirt off. Brushing will force dirt into the filter fibers.
3. Replace the element if it becomes excessively dirty. You can order/purchase paper elements through Tempest or your local hardware home improvement store.

COOLING SYSTEM

Frequently remove dirt and debris from the cooling fins, air intake screen, levers and linkage. This will ensure adequate cooling and correct engine speed. Refer to the engine manufacturer's owner's manual for additional cooling system information.

SPARK PLUG

A correctly firing spark plug is essential for the blower to operate properly. Check the engine spark plug every six (6) months or every 100 hours by following the listed procedures.

1. Clean the area around the spark plug.
2. Remove and inspect the spark plug.
3. Replace the spark plug if the electrodes are pitted, burned, or the porcelain is cracked. Check the electrode gap with a wire feeler gauge and set to the engine manufacturer's specifications.
4. Make sure the spark plug washer is in good condition, and start threading the spark plug by hand to prevent cross threading.
5. After the spark plug is seated, tighten with a spark plug wrench to compress the washer.

CARBURETOR

All carburetors comply with US federal & state regulations and are preset by the engine manufacturer. Engine performance may differ at various altitudes and climates. If you feel that the carburetor on your blower needs adjusting contact Tempest or your local engine dealer.

EMISSION CONTROL SYSTEM

US State regulations require that all manufacturers of gas powered engines furnish written instructions describing the operation and maintenance of the emission control systems. These instructions vary depending on engine type. Please refer to your engine manufacturer owner's manual for specific information and instructions.

POWER BLOWER™ TROUBLESHOOTING

Various factors can contribute to or be the sole cause of problems for gas *Power Blowers™*. This section will identify some of these problems and provide solutions to correct them.

BLOWER FAILS TO START

- Check for fuel in the tank; make sure the fuel shut off valve is open.
- Check the fuel line to determine if the carburetor is getting fuel.
- Check to see if the fuel tank has been overfilled. Too much fuel in the tank, or tilting the unit too far can clog the charcoal filter located in the fuel cap, inhibiting fuel flow.
- Check the oil level, HONDA® engines are quipped with automatic oil alert systems. The engine will not start if oil is low.
- Check the spark plug for a spark:
 1. Remove the spark plug wire, clean any dirt from around the spark plug base and remove the plug.
 2. Install the spark plug into the plug cap.
 3. Ground the plug to the engine and pull the starter to see if a spark jumps the gap. **DO NOT HOLD THE SPARK PLUG IN YOUR HANDS;** hold the spark plug cap or wire.
 4. If a spark is present, replace the spark plug and wire then try starting the engine.
- If the blower still does not start, contact Tempest or your local engine dealer.

POOR BLOWER PERFORMANCE

- Check the air filter for cleanliness, clean if dirty.
- Make sure the blade is tight on the output shaft
- If the fuel is more then two months old, replace the fuel with fresh fuel.
- If blower is still not performing as normal, contact Tempest at 800.346.2143 or response@tempest.us.com.

BLOWER MOVEMENT OR "WALKING"

- Adjust the rubber footpads on the back of the blower by turning them either in or out.
- Adjust the side that is walking. This will help to evenly distribute the weight of the blower to all four points of the frame.
- Most blowers will walk if not running at full speed, make sure the blower is running at full speed.
- Make sure the blower is sitting flat and not on small rocks or other objects.
- If blower is still walking, contact Tempest at 800.346.2143 or response@tempest.us.com.



Replacement Parts

Direct Drive Gas
Power Blowers

For Technical Support:
1-800-346-2143
response@tempest.us.com

Please specify part number and
serial number of blower when
ordering parts.

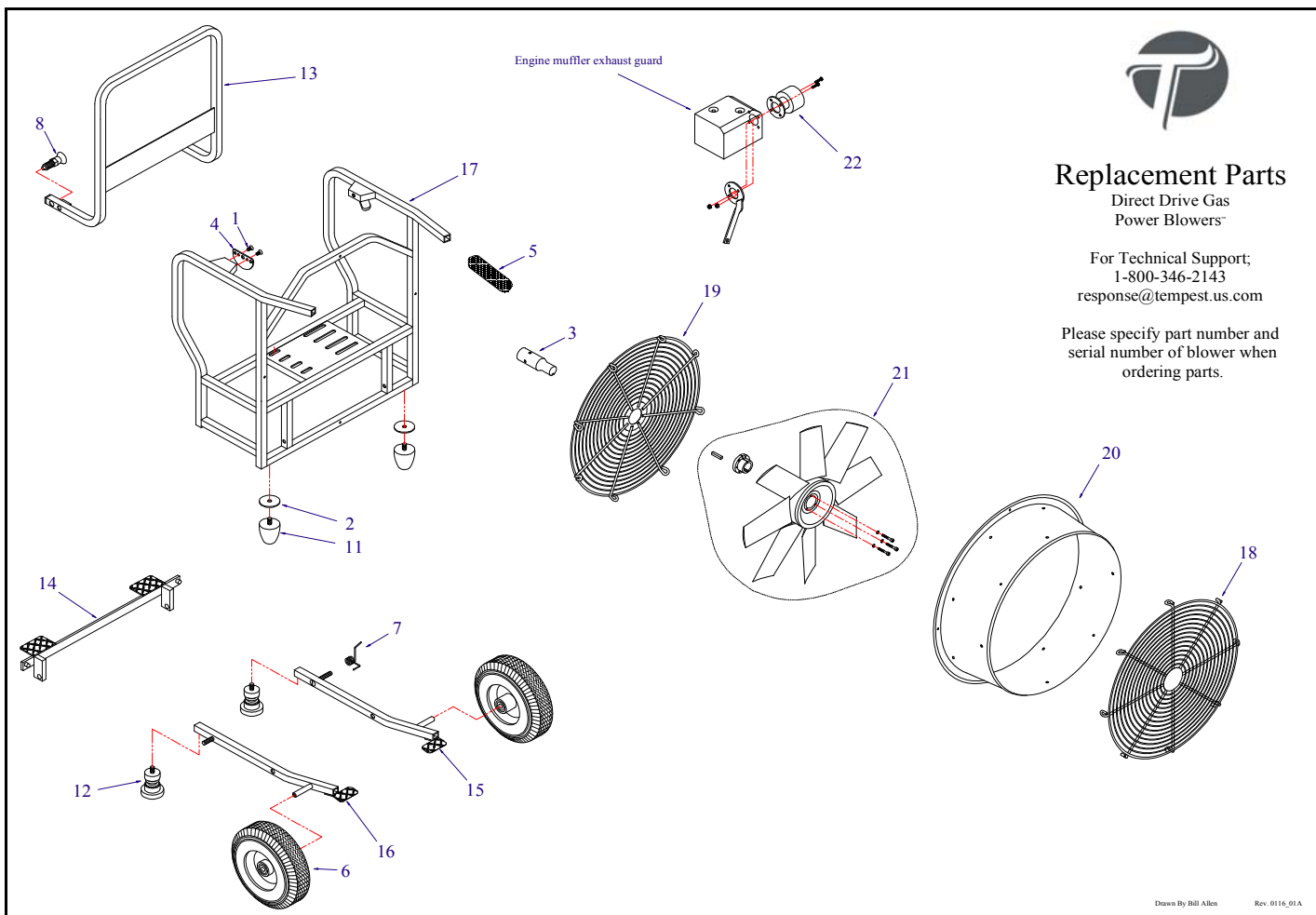

Drawn By Bill Allen Rev. 0116_01A

Item #	Description	DD-16-H-4.8	DD-18-H-4.8	DD-21-H-5.5	DD-24-H-5.5
		Part No.	Part No.	Part No.	Part No.
1	1/4 X 1/2 FLAT SOC C/S ZINC	100-079	100-079	100-079	100-079
2	WASHER 3/8 X 2 FENDER HVY Z	120-037	120-037	120-037	120-037
3*	SHAFT 1" EXTENSION 4140 H.T.	170-004K	170-004K	170-004K	170-004K
4	HANDLE BRACKET	220-069	220-069	220-069	220-069
5	GRIP BASIC BLOWER HANDLE	220-248	220-248	220-248	220-247
6	WHEEL FLAT FREE	240-008	240-012G	240-012G	240-012G
7	SPRING TORSION	300-019	300-018	300-018	300-018
8	SPRING PLUNGER W/HANDLE	300-170	300-170	300-170	300-170
NI	HONDA ENGINE	350-004	350-004	350-016	350-016
11	FOOT TAPERED	580-006	580-006	580-006	580-006
12	SPRING ASSEMBLY	600-001	600-001	600-001	600-001
13*	HANDLE RED	600-677K	600-678K	600-679K	600-680K
14*	WIN STEP RED	600-683K	600-684K	600-687K	600-689K
15*	LEG ASSEMBLY LEFT DARK GREY	610-1001K	610-1020K	610-1020K	610-1020K
16*	LEG ASSEMBLY RIGHT DARK DREY	610-1002K	610-1021K	610-1021K	610-1021K
17*	FRAME DARK GREY	610-1300K	610-1320K	610-1340K	610-1360K
18	FRONT GRILLE DARK GREY	610-1400K	610-1420K	610-1440K	610-1460K
19	REAR GRILLE DARK GREY	610-1401	610-1421	610-1441	610-1461
20*	SHROUD, RED	705-100	705-105	705-110	705-115
21*	BLADE ASSEMBLY	705-272	705-283	705-262	705-271
22*	EXHAUST EXTENSION KIT FOR HONDA	725-047	725-047	725-039	725-039

* denotes item includes necessary hardware for installation

NI Not Illustrated

This document contains proprietary information and intellectual property that cannot be reproduced or altered, in whole or in part, without the written consent of Tempest Technology Corp.

Copyright 2016 - All Rights Reserved

Information and Material Subject to Change Without Notice

WARRANTY INFORMATION

Except as otherwise set forth below, any claim by Customer with reference to the Goods sold shall be deemed waived by the Customer unless submitted in writing to Tempest within the earlier of (i) five (5) business days following the date Customer discovered, or by reasonable inspection should have discovered, any claimed breach of the foregoing warranty, or (ii) thirty (30) calendar days following the date of shipment. Any cause of action for breach of the foregoing warranty shall be brought within one (1) year from the date the alleged breach was discovered or should have been discovered, whichever occurs first.

Limited Power Blower Warranty

Tempest warrants to the original purchaser that all Tempest gasoline and electric powered blowers (except the engine or motor and drive) will be free from original defects in workmanship and material, under normal-use conditions, and Tempest will replace any defective power blower part (except the engine or motor and drive) if returned during the applicable warranty period, for the time frame indicated below:

Firefighting Industry:
Two (2) years from date of shipment
Industrial/Rental Industry:
One (1) year from date of shipment

Blower Engine / Motor & Drive Warranty

The engines manufactured by Honda® are covered by a separate manufacturer's warranty for a period of two (2) years.

Note: Unauthorized repair or modification of the factory assembly or parts voids the warranty.

All information provided in this operations manual is subject to change without notice. Please refer to our website for the most recent sales terms and conditions.

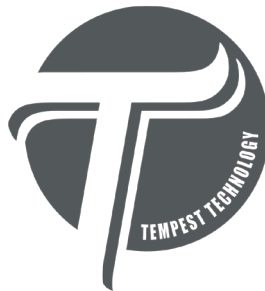

Manufacturer

Tempest Technology Corporation

4708 N. Blythe Avenue, Fresno, CA 93722 USA

t: +1.559.277.7577 • f: +1.559.277.7579 • response@tempest.us.com

European representative

Groupe Leader ZI des hautes vallées 76930 Octeville sur mer FRANCE

t: +33.235.530.575 • f: +33.235.531.632 • info@groupe-leader.com



www.tempest.us.com