

OWNER'S MANUAL

SHADOW™ Smoke Machines
Nightfall



www



TABLE OF CONTENTS

Introduction	2
Important Safeguards.....	2-4
Unpacking.....	5
Controls.....	5-6
Setting Up	7
Fluid Setup	7
Power Connections	7
Operating the Machine.....	8-11
Powering On	8
Heating	8
Control Options.....	8
Manual Control via the Detachable Remote Control Panel	8
Multi-Link	8
Using the Remote Control Panel	8
Using Timers.....	8-9
Using Multi-Link	9
Changing Fluid	9
Running Dry	10
Priming the System	10
Powering Down.....	10
Ducting Smoke.....	10
Troubleshooting	11
Maintenance	12
Exterior Cleaning.....	12
Maintaining the Heat Exchanger	12
Using the Air-Input Connection.....	12
Storage and Shipment	13
Specifications.....	13-14
Warranty	15
CE Certificate of Conformity	16

INTRODUCTION

Congratulations on your purchase of the Shadow Nightfall Smoke Machine. The Nightfall offers the perfect balance of performance, reliability and affordability.

To ensure efficient and safe operation, please take a few moments to read this manual completely.

The Shadow Nightfall is a thermal aerosol generator designed for continuous, variable smoke output. This machine is one part of a system, the other component being Rosco's Smoke Simulation fluid. ALL ROSCO FOG AND HAZE FLUIDS ARE UNIQUE WATER-BASED FORMULATIONS THAT CONTAIN NO PETROLEUM DISTILLATES AND ARE SAFE WHEN USED ACCORDING TO INSTRUCTIONS. The operating temperature, pump pressure, and output nozzle of the Nightfall have been specifically designed and engineered together to maximize the aerosolization of Rosco fog fluids.

Do not use any fluids in the Nightfall other than genuine Rosco Smoke Simulation Fluids as they have not been tested for optimal performance and safety considerations. Doing so may damage the machine and will void the warranty.

Note: The terms "fog," "haze" and "smoke" are used interchangeably throughout this manual. Tempest Shadow Smoke machines do not produce actual smoke, only a mist or aerosol.

IMPORTANT SAFEGUARDS

READ AND UNDERSTAND THESE SAFETY PRECAUTIONS BEFORE OPERATING THE MACHINE. FAILURE TO PROPERLY FOLLOW THESE PRECAUTIONS MAY LEAD TO A FIRE, ELECTRICAL SHOCK, OR BURNS.

FOG FLUID HEALTH CAUTION: VAPOR FROM THIS FLUID, LIKE ANY OTHER COMMON MATERIAL IN A VAPORIZED STATE, MAY BE IRRITATING TO OR CAUSE ALLERGIC SYMPTOMS IN SOME PERSONS WITH ALLERGENIC SENSITIVITY. DO NOT EXPOSE AT CLOSE RANGE TO KNOWN ASTHMATICS.

The following symbols are used to identify important safety information:



Caution! Safety hazard. Risk of personal injury.



Caution! Burn hazard. Hot surface. Do not touch

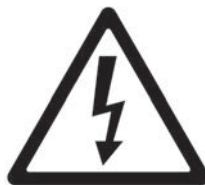

Danger! Hazardous voltage. Contact will cause electric shock.



Caution! Fire hazard.



Preventing Electric Shock

- This machine uses electrical power at common commercially available voltages. When directly contacted, such voltages are hazardous to human life. All precautions commonly applicable to the use of electric power generally are applicable to the use of this machine.
- This machine is designed to operate from three-wire power systems where one of the wires is a safety ground. DO NOT disconnect the safety ground or use extension cords or “cheater” plugs to connect this machine to a two-wire system. Operation without a safety ground may result in a hazardous electrical shock.
- Check the current and voltage rating of your machine. Extension cords must be properly sized and rated for voltage, current and length. Check your local electrical code for the correct gauge extension cord. If an extension cord shows signs of wear or gets warm to the touch, discontinue its use and obtain a cord with a higher current rating. Improper extension cords are not only hazardous, but may result in poor machine performance due to excessive voltage drop.
- Never use any machine that shows signs of improper use. Even slight damage may be an indication of a major problem. If the machine looks questionable, use it only under strict observation. If the machine shows any unusual behavior, disconnect machine immediately from power and send machine to a Service Center for repair.
- Disconnect unit from power source before servicing and when not in use.



Preventing Burns and Fire



- During the warm-up phase and during operations, people should not stand within three feet (one meter) of the front of the machine. Flammable material like paper, fabric, etc., should never be placed directly on or around this equipment, or any other electrical device with a heating element.
- The fog should be blown into an open space and should not be directed at people or objects. Never blow fog on hot surfaces, into glowing heating elements or into open flames. The normally non-flammable and non-toxic fog could react on very hot surfaces and be burnt or decomposed.
- Do not operate the machine in a tightly confined space where the ambient temperature might exceed 135° F (57° C). A continuous flow of air is required to maintain temperature within the machine housing. Sensitive electronic components deteriorate rapidly under high heat conditions. Operation of the machine in an enclosure of less than ten cubic feet (one cubic meter) is dangerous, and automatically voids the warranty.
- **Enclosing any heating device so it is invisible to the operator creates a potential fire hazard, no matter what the ambient temperature of the enclosure. To do so with any high-amperage device is to assume substantial risk. Tempest strongly recommends against it.**



Safety Precautions

- In any facility, the fog concentration should be controlled. The fog should never mask emergency exits, safety signs, staircases or other safety constructions.
- After long use, or if the machine is not properly set, some liquid droplets or wet area may appear in front of the machine's outlet. This liquid should be wiped up to prevent a condition where someone might slip and fall.



Preventing Improper Operation

- Unauthorized repair or alteration of any safety devices can lead to improper operation and accidents. Repairs should be performed only by an authorized Service Center.
- **Use of any fluid other than Rosco Smoke Simulation fluid or modification or attempted unauthorized repair of the machine will immediately invalidate the warranty.**
- Machines are designed for continuous use over an 8-hour day, but to protect components, it is wise to turn off the machine when it is not in use. In permanent installations, it is advisable to equip the circuit with a night cut-off device.

Additional Precautions: Do's & Don'ts

- Do Read the entire manual before operating the machine and pay particular attention to all CAUTIONS AND WARNINGS.
- Do Use an extension cord that is properly rated for voltage, current and length, and is free from nicks, cuts or other signs of wear.
- Do Check to see that the machine is clean and free of foreign objects before each operating period.
- Do Ensure that the machine is adequately ventilated.
- Do Use proper caution when handling hot surfaces.
- Do Use the minimum amount of fog required to achieve the desired effect.
- Do Not Use the machine near a person who has asthma or similar inhalation disorder.
- Do Not Use any foreign substances in the machine.
- Do Not Use a machine that is damaged or operating improperly in any way.
- Do Not Use a machine that leaks fluid from the housing.
- Do Not Leave the machine switched on for prolonged periods of time without producing fog.
- Do Not Enclose the machine.
- Do Not Install the machine in such a fashion that the operator cannot see the whole machine, including the indicator lights.
- Do Not Touch the shielded nozzle of the machine. Allow sufficient cooling time after operation before attempting to perform maintenance or storage.
- Do Not Direct the fog output continuously against nearby surfaces. This may eventually cause fluid to re-condense.

UNPACKING

Your Shadow Nightfall requires no assembly. *Note: 230 volt machines are shipped with bare leads at the end of the power cord. A proper electrical connector must be attached based on the local power requirements.* Carefully remove the machine from the box. Ensure that no tape or packing materials are stuck to the machine. Stray packing materials that remain attached to high temperature areas of the machine could melt or burn during operation. In particular, ensure that the area around the nozzle is free of any materials or debris.

CONTROLS

Heat Indicator

A red indicator light that illuminates when machine is heating in order to achieve optimal temperature for producing smoke.

Ready Indicator

A green indicator light that illuminates when the minimum temperature for producing smoke has been achieved. *Note: All indicator lights will switch off if Standby mode is engaged.*

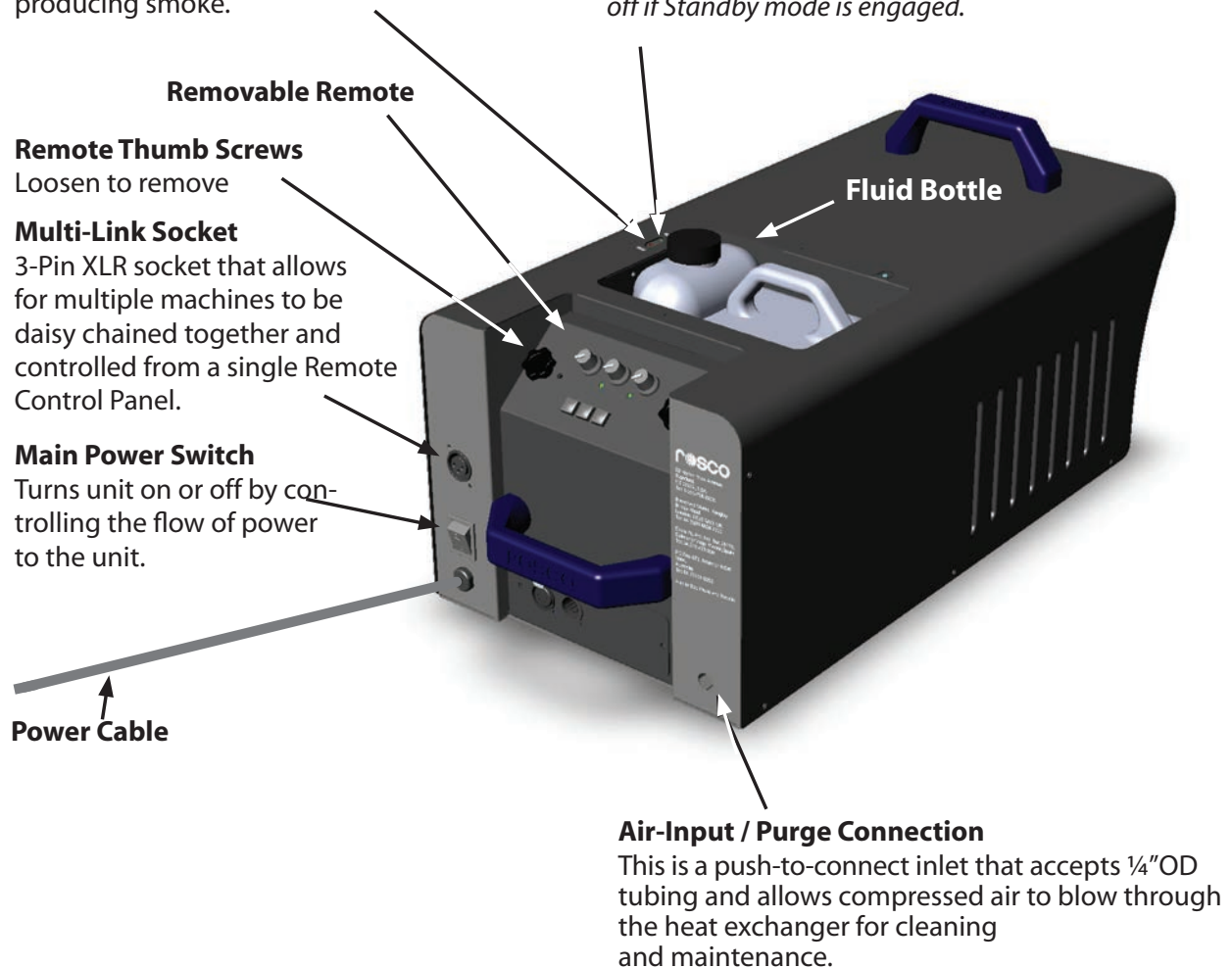

CONTROLS

Fog Level Knob

Rotate to set the desired amount of smoke output. Higher numbers indicate more smoke. Output is controlled by pump speed increasing and sending more smoke fluid into the heat exchanger.

Fog Off Knob

Used only when timer control is engaged. Rotate to set the desired time interval that the machine will wait while NOT producing smoke.

Fog On Knob

Used only when timer control is engaged. Rotate to set the desired time interval that the machine will produce smoke. During smoke production, the Power Indicator light will flash.

Power Indicator

A red indicator light that illuminates when the Main Power Switch is in the "On" position to indicate the machine is properly receiving power and Standby mode is disengaged. The red Power Indicator light flashes while fog is being produced.



Fog Button

Press and release to start making smoke. Press and release again to stop making smoke. *The Fog Button is disabled if Standby mode is engaged.*

Standby Button

Press and release to suspend heating and operation of the machine without turning off the Main Power Switch. The Power Indicator light on the Remote Control Panel will go out when in Standby mode. Press and release again to disengage Standby mode. Once Standby mode is disengaged, the Power Indicator light on the Remote Control Panel will come back on.

Timer Indicator

A green indicator light that illuminates when Timer mode is engaged by pressing the Timer Button. Turns off when Timer mode is disengaged.

Timer Button

Press and release to engage the timer control functions. Timer Indicator light will come on. Press and release again to disengage timer functions. Timer Indicator light will go out. *Note: The Timer Button disabled if Standby mode is engaged.*

OPERATING THE MACHINE

Powering On

Make sure the unit is plugged in. Turn on the Main Power Switch that is located next to the power cord on the rear of the machine. The red Power Indicator light on the Remote Control Panel will illuminate. If the Power Indicator light does NOT illuminate, press and release the Standby Button on the Remote Control Panel.

Heating

When switched on, the red Heat Indicator light will illuminate and the machine will begin to heat up to its optimal temperature. The initial heating cycle will take 7-10 minutes. When the green Ready Indicator light comes on, the machine is ready to make smoke.

Control Options

There are several methods of controlling the Nightfall, including: Manual Control via the Remote Control Panel and Multi-Link control that allows multiple machines to be controlled from a single Remote Control Panel.

Manual Control via the Detachable Remote Control Panel that is included with each machine. An operator can control the unit at the machine, or from a distance using the included 3-pin cable. The Remote Control Panel can be used to set smoke output volume, power the machine on and off using Standby mode, and set a repeating, timed cycle of on/off operation.

Multi-Link allows up to 4 machines to be linked together via 3pin XLR cables (not included) and controlled by a single Remote Control Panel.

Using the Remote Control Panel

The Remote Control Panel can be operated directly on the machine or detached from the unit and used at a distance. To detach the Remote Control Panel from the unit, loosen the thumb screws and lift the panel from its recessed mount. A 15 foot (4.5m) cable is provided to allow the machine to be operated at a distance. If needed, a longer 3-pin XLR cable can be used or joined to the existing cable. Do not exceed a maximum distance of 165 feet (50 m) from remote to machine.

When the green Ready Indicator light is illuminated, the Nightfall is ready to make smoke. Press and release the Fog Button to begin producing smoke. The red Power Indicator light will flash to indicate the machine is operating. To stop making smoke, press and release the Fog Button again. Adjust the Fog Level knob to increase or decrease the amount of smoke produced.

The Standby Button allows the machine to be “turned off” from the remote without using the Main Power Switch. In Standby mode, the machine will not reheat or make smoke, the pump remains unpowered and all indicator lights will switch off. To engage Standby mode, press and release the Standby Button. The red Power Indicator light will turn off. To disengage Standby mode, press and release the Standby Button again and the red Power Indicator light will turn back on. Once Standby mode is disengaged, the machine will immediately start heating in preparation to make smoke. *Note: If no remote is connected and no DMX signal is detected, the machine will not heat.*

Using Timers

The timer controls allow you to set the machine to produce smoke in timed intervals without an operator. To engage the timers, press and release the Timer Button. The green Timer Indicator light will illuminate and the machine will begin to produce smoke at the level set by the Fog Level Knob, and the red Power Indicator light will flash to indicate the machine is operating.

Rotate the Fog Off Knob to adjust the period of time that the machine waits before starting to produce smoke again. The numeric settings on the timer knobs are relative settings and do not correspond to specific seconds or minutes. See the table below for an approximation of the time duration corresponding to each tic on the knob.

The machine will cycle on and off indefinitely until the Timer Button is turned off. If the Fog Button is pressed while in Timer mode, this will override any timer settings and the machine will produce smoke. When the Fog Button is disengaged, the timer settings resume, continuing its On/Off cycle as if not interrupted.

KNOB SETTING	TIMER SETTING
1 - 4	1 to 4 seconds
4 - 5	4 to 16 seconds
5 - 7	16 to 64 seconds
7 - 9	64 to 250 seconds

Using Multi-Link

In some instances, it may be preferable to control and synchronize multiple machines from a single Remote Control Panel. This can be quickly and easily accomplished using the Nightfall's built-in Multi-Link capabilities. Up to four Shadow Nightfall Machines can be connected and controlled via a single controller. Connect a 3-pin XLR cable (not included) to the Multi-Link port on the rear of the first machine in the daisy chain. This unit becomes the "Head Machine" and its Remote Control Panel will control the other units in the chain.

Remove and detach the Remote Control Panel and its 3-pin XLR cable from the second machine. Connect the plug of the cable from the Head Machine into the remote port of the second machine where the Remote Control Panel had previously been connected.

Repeat this process to connect a third and/or fourth machine. No additional set-up is required. The Remote Control Panel attached to the head machine will operate all machines in the Multi-Link as if they are the same.

Note: The maximum length of the daisy chain, from the remote of the Head Machine to the final machine is 165 feet (50 m).



Changing Fluid

The Nightfall consumes 3.6 liters of fluid per hour at its maximum rate. When the fluid in the bottle has been depleted enough that the tube can no longer stay submerged, it is time to change fluid bottles.

It is recommended that you stop making fog when changing fluid bottles. Once smoke production has halted, simply unscrew the fluid tube cap from the empty bottle and remove the tube. Take care to avoid dripping fluid onto the machine case or ground nearby, as it can be slippery. Replace the empty bottle with a new bottle of Rosco Smoke Simulation fluid, insert the fluid tube insuring that the filter at the end of the tube is fully submerged, and reattach the fluid cap. Resume making smoke.

Running Dry

Do not allow the machine to run dry of fluid. If the machine does run out of fluid it will stop producing smoke and the green Ready Indicator light will indicate a Fluid Out condition with a fast double-flash. In order to reset the Fluid Out condition, power cycle the machine by turning the Main Power Switch off, wait 5 seconds, and then turn the Main Power Switch back on. After inserting the tube in a new bottle of smoke fluid, you will need to prime the machine to remove airlocks in the fluid pipework of the machine.

Priming the System

To prime the machine, turn the Fog Level Knob to Zero, then hold down the Fog Button and turn the knob to maximum. Keep the button held until the smoke output is strong and steady. Then turn the Fog Level knob back to the required output level and release the Fog Button.

Powering Down

After use, allow the machine to sit for several minutes before switching the Main Power Switch to off. Turning off the power switch during smoke production can cause damage to the heat exchanger. Allow machine to cool completely before packing or storing. *Note: The nozzle of the machine may remain hot for up to 10 hours after power is shut off.*

If the machine will be unused for an extended period of time, follow the Storage and Shipment instructions listed under Maintenance to prepare the machine for long-term storage.

DUCTING SMOKE

It is often desirable to duct smoke from the machine to another location. This can be accomplished using flexible hose ("dryer hose") or similar large diameter ducting such as 4in (100mm) PVC. Avoid sharp bends in the duct, which can create turbulence or back flow.

The duct should be positioned no closer than 2in (50mm) to the nozzle. An open airflow between the nozzle and opening of the duct is crucial to allow for aerosolization and create proper airflow. Placing ductwork or tubing directly over the nozzle or nozzle guard will cause damage to the machine and will void the warranty. Take all precautions to avoid fire hazards as the nozzle is extremely hot.

In some instances, it is desirable to use a fan to accelerate the smoke through the ductwork. Never run smoke through the blades of a fan as the action of the impeller will cause condensation of fluid particles. To properly use a fan, create a vent in the ducting system such as a and introduce a fan at the vent point. This will create a low pressure point that "pulls or pushes" the smoke through the ductwork.

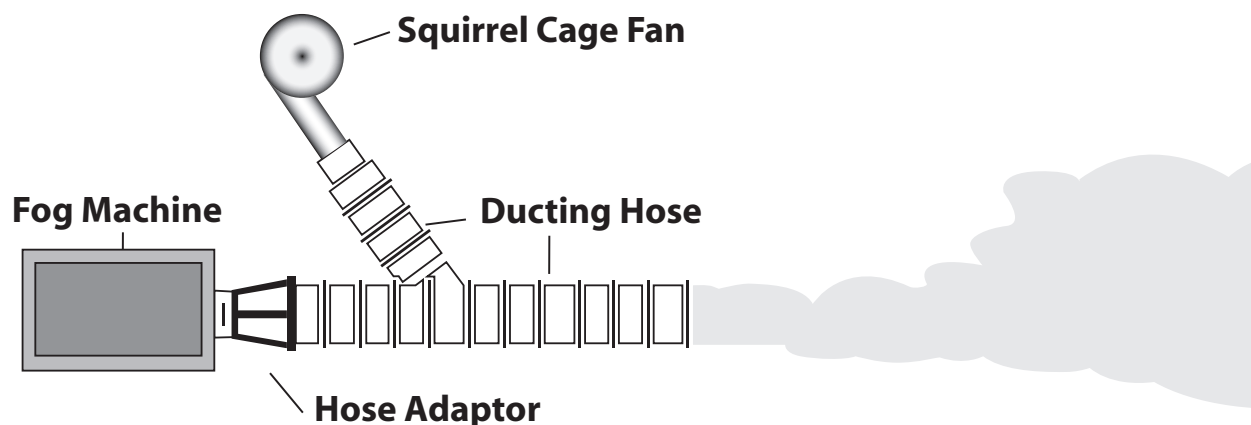

Contact Tempest for more advice on ducting smoke.

TROUBLESHOOTING

Problem	Probable Cause(s)	Suggested Remedy
Machine does not heat up	Machine is not turned on	Ensure Main Power Switch is on
	Machine is in Standby mode	Press Standby Button on The Remote Control Panel. Red Power Indicator light on the Remote Control Panel will illuminate.
	No power at AC cable inlet	Check to make sure machine is plugged in properly. Check the circuit breaker.
	Machine has overheated and internal thermal fuse is blown	Contact nearest Service Center for repair
	Main fuse is blown	Contact nearest Service Center for repair
Machine will not produce smoke when Fog Button is pressed	Machine not turned on	Ensure Main Power Switch is on
	Machine not at operating temperature	Wait 7-10 minutes until green Ready Indicator light illuminates
	Fog level set to zero	Rotate Fog Level Knob clockwise
Smoke output is weak	Smoke output control is too low	Rotate the Fog Level Knob clockwise
	Fluid filter above fluid line	Ensure filter is submerged
	Machine requires priming	See the Priming the System section of the manual
	Heat exchanger is clogged	Contact nearest Service Center for repair
Machine produces smoke intermittently when fog button is not pressed	Timer is engaged	Turn timers off by pressing Timer Button. Green Timer Indicator light should not be illuminated.

Additional help and information can be found contacting Tempest.

MAINTENANCE

Before servicing the Shadow Nightfall, read and observe all the precautions listed in the Important Safeguards section on pages 2-4 of this manual. *Note: Any service that is NOT described in the section below must be carried out by a Rosco service technician. Contact Tempest for more information on your repair and service needs.*

Exterior Cleaning

Excessive dust, fluid residue, and dirt build-up will degrade the performance of the machine and may cause overheating to occur. To maintain adequate air flow and cooling, the outer casing and air vents of the machine must be cleaned periodically. Damage caused by lack of cleaning is not covered by the product warranty.

- Unplug the machine from power and allow the unit to cool completely before cleaning.
Note: The output nozzle may remain hot for up to 10 hours after use.
- Remove dust from the air vents with a soft brush, cotton swab, vacuum or compressed air.
- Clean any fluid residues from the fog output area of the machine using a damp cloth.
- Clean the outer casing with a damp cloth only.

Maintaining the Heat Exchanger

The heat exchanger is the core element in a fog or haze machine that transforms fluid into an aerosolized fog/haze. This component operates under extreme temperatures and pressures and should be cleaned periodically to ensure optimal performance. The Air-Input Connection was designed to provide a fast and efficient method of cleaning the heat exchanger by purging it of residual fluid and build up using compressed air. For lasting performance, Tempest recommends purging the heat exchanger once a week while in production, and before storing the machine for extended periods of time. Tempest does not recommend the use of any purified waters, chemicals or fog machine cleaners. Use of these materials will void the warranty.

Using the Air-Input Connection

You must have a source of compressed air from an air compressor or external air tank available. Compressed air must be clean and dry.

Allow the machine to heat until the green Ready Indicator light has illuminated.

Using the push-to-connect fitting, connect a ¼" OD tube from your air source by inserting the tube into the Air-Input Connection located on the rear panel of the machine. Alternately, you can use a blow gun attachment, or similar device with a stepped nozzle, that is held against the orifice of the Air-Input Connection.

Set the air pressure to a maximum of 60 psi. Higher air pressure may damage the internal plumping components. Blow air into the Air-Input Connection for 30 seconds, or until no additional haze or fluid exits the nozzle.

CAUTION: Keep people and objects at least 3ft (1m) away from the nozzle of the machine during air purging.

To release the tubing from the push-to-connect fitting, push back on the fitting collar and pull to release the air line.

Storage & Shipment

Before storing the machine for an extended period of time, ensure the following:

- Fluid bottle has been removed and securely capped
- Proper cleaning of exterior as described above
- Proper purging of the heat exchanger as described above
- Machine is properly boxed or covered to avoid dust build up on internal components
- If shipping, use original packaging or comparable protection to avoid damaging the machine in transit

SPECIFICATIONS

Physical

Length	22.59" (573.8 mm)
Width	10.94" (278 mm)
Height.....	9.82" (249.5 mm)
Dry weight.....	24.25 lbs (11 kg)

Performance

Operating time	continuous
Warm up time	7-10 minutes

Control and programming

Control options	timer remote
-----------------------	--------------

Fluid system

Capacity	120v - 4 liters / 240v - 5 litres
Fluid consumption	3.6 liters / hour

Connections

Remote / Multi-Link.....	3 pin XLR
AC power	Fixed power cable

Electrical

AC voltage	120V / 230V, 50/60Hz
Main fuse (120V US version)	10AT
Main fuse (230V EU version)	5AT

Thermal

Maximum ambient temperature.....	40°C (104°F)
Exterior surface temperature, steady state, at 20°C ambient.....	40°C (104°F)

Approvals

European EMC:.....	EN61000-6-3,EN61000-3-2,EN61000-3-3,EN50366
European safety:.....	EN 60 335-1
Immunity:	EN61000-6-1, EN61000-4-2,EN61000-4-3
ETL approvals (cETLus) pending	UL60335-1, CSA-E60335-1

Information in this document is subject to change without notice and does not represent a commitment on the part of Tempest.

Dimensions

Dimensions are shown in [inches] and millimeters

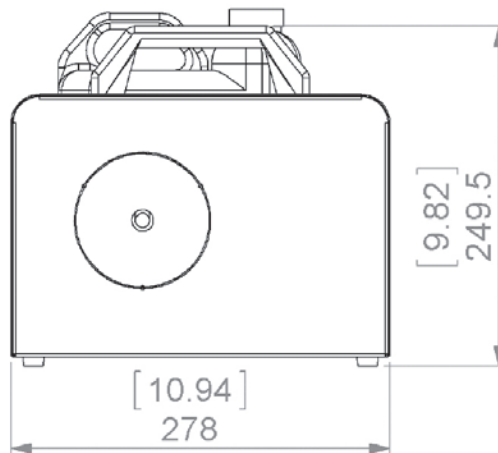
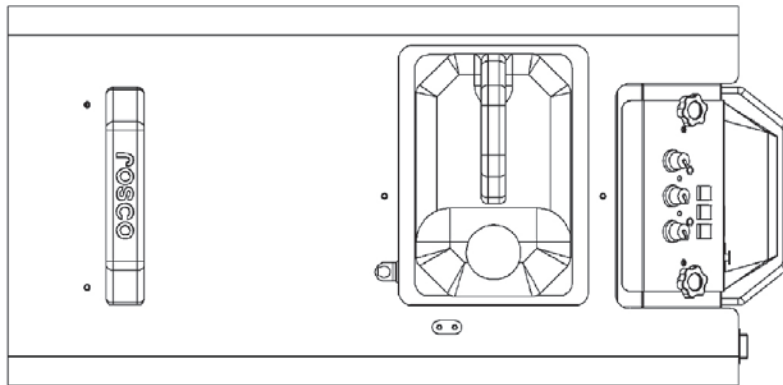
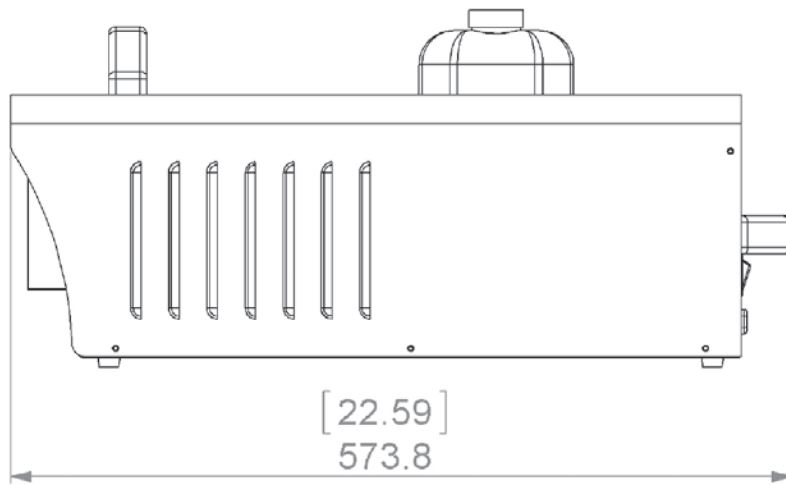

1 YEAR LIMITED WARRANTY

Rosco Laboratories warrants to the first retail purchaser that this Product will be free from defects in workmanship and material for a period of twelve (12) months from the date of original purchase. For warranty service you must be able to provide proof of purchase.

Should this Product prove defective during the warranty period, please contact your local Rosco office for return authorization. No warranty service will be performed without Return Authorization. At Rosco's sole discretion, covered Products will be repaired or replaced with new or refurbished equipment or a model of like kind and quality. Exchanged or replaced parts and Products assume the remaining warranty period of the original Product covered by this limited warranty.

You are responsible for securely packaging the defective Product and returning it to Rosco as per the instructions on the Return Authorization. Within North America, Rosco will ship the repaired or replaced Product to you freight prepaid. Shipments to other locations will be made freight collect. Do not return fog machines with fog fluid.

This warranty is not transferable and does not extend beyond the first retail purchase of the Product. This warranty does not cover damage to the Rosco product caused by parts not manufactured, distributed or certified by Rosco. Rosco is not obligated to provide warranty service should the product fail to be properly maintained or fail to function properly as a result of misuse, abuse, improper installation, neglect, improper shipping, damage caused by disasters such as flood, fire and lightning, improper electrical current or connection or service other than by a Rosco Authorized Servicer. If a claimed defect cannot be identified or reproduced, you will be held responsible for the costs incurred. Unless otherwise stipulated by state law, all warranties expressed or implied are limited to the twelve (12) month period of this warranty.

THE WARRANTY AND REMEDY PROVIDED ABOVE ARE EXCLUSIVE AND IN LIEU OF ALL OTHER EXPRESS OR IMPLIED WARRANTIES INCLUDING BUT NOT LIMITED TO THE IMPLIED WARRANTIES OF MERCHANTABILITY, NON-INFRINGEMENT OR FITNESS FOR A PARTICULAR PURPOSE. EXCEPT AS PROVIDED IN THIS WRITTEN WARRANTY AND UNLESS EXCLUSIONS ARE SPECIFICALLY FORBIDDEN BY STATE LAW, NEITHER ROSCO NOR ITS AFFILIATES WILL BE LIABLE FOR ANY LOSS, INCONVENIENCE, OR DAMAGE, INCLUDING DIRECT, SPECIAL, INCIDENTAL OR CONSEQUENTIAL DAMAGES, INCLUDING INJURY TO PERSONS OR PROPERTY, RESULTING FROM THE USE OR INABILITY TO USE THE ROSCO PRODUCT, WHETHER RESULTING FROM BREACH OF WARRANTY OR ANY OTHER LEGAL THEORY.

•NOTE: USE OF ANY FLUID OTHER THAN A ROSCO BRAND FLUID WILL VOID THE WARRANTY.



EC Declaration of Conformity

Date : 1 November 2014

Manufacturer : Rosco Laboratories, Inc.

Address : 52 Harbor View Avenue, Stamford, Connecticut 06902, U.S.A.
Tel : (203) 708 8900 Fax : (203) 708 8919 Eml : info@rosco.com

Product Name : SHADOW™ Nightfall (by Rosco)

Product Type : Smoke Effects Machine

These products meet the requirements, where applicable, of the following EC Standards and as such, comply with the EMC and LVD directives of the European Community:

EN 61000-6-3:2007	Generic Emission Standard for residential and light Industrial environments.
EN 61000-6-1:2007	Generic Immunity Standard for residential and light Industrial environments.
60335-1:2002+A15:2011	Safety of household and similar electrical appliances
BS EN 62233:2008	Electromagnetic fields.

These standards reference the following European standards:

Emissions:

EN 55 022 /B	RF voltage and field strength
EN61000-3-3	Flicker
EN 55 014	RF voltage (discontinuous)

Immunity:

EN 61000-4-2	Electrostatic discharge to case
EN 61000-4-4	Common mode fast transients (AC and DC ports)
EN 61000-4-5	Surge
EN 61000-4-11	Voltage dips and interruptions
EN 61000-4-6	RF common mode

These standards also meet the requirements of CISPR 22 and 14.

Authorised Signatory : Joshua Alemany, Director of Global Marketing

Place and Date : Stamford, Connecticut - 1 November 2014

Signed:



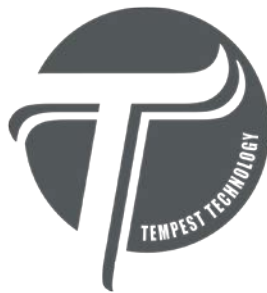

Tempest Technology Corporation

4708 N. Blythe Avenue, Fresno, CA 93722

t: 559.277.7577 • f: 559.277.7579 • response@tempest.us.com

www.tempest.us.com